

# nXDS DRY SCROLL PUMPS

 **EDWARDS**





# EDWARDS THE PARTNER OF CHOICE

**Edwards is a world leader in the design, technology and manufacture of vacuum pumps with over 95 years' history and more than 75 years' manufacturing experience.**

Edwards believes in delivering results that bring value to our customers by using our breadth of industry experience to identify and apply solutions to your problems. Using the most innovative and up-to-date modelling techniques, we can optimise the pumping configuration for customers to provide a system design giving the maximum performance in the most reliable and cost-effective way.

# THE INTELLIGENT CHOICE

## Edwards nXDS is the great new shape of dry vacuum pumping

The nXDS has taken scroll vacuum technology to the next level. Improved performance, exceptional pumping capability, quiet operation and extended service intervals make nXDS the ultimate dry choice.

Quiet operation

### **Better working environment**

Hermetically sealed for a lubricant-free vacuum environment

### **Contamination free process and no oil to dispose of**

Low power consumption

### **Low cost of ownership**

Intelligent and easy to use controls

### **Flexibility of operation**

Superior vapour handling

### **Wider range of applications**

Long service intervals

### **Maximised up-time**

## Applications

You can be assured Edwards has the application expertise and the vacuum pump or integrated system solution to meet your needs.

### **Mass spectrometry**

- GCMS, LCMS, ICPMS, MALDI, RGA, surface science, leak detectors

### **Electron microscopy**

- TEM, SEM, sample coaters

### **Sample preparation**

- Gel dryers, glove boxes, rotary evaporators, centrifuges

### **Research and development**

- Chamber evacuation, coating systems, turbopump backing

### **High energy physics**

- Beam lines, accelerators, mobile pump carts, turbopump backing, laser evacuation

### **Industrial**

- Gas recovery and recirculation, glove boxes, brake line and air conditioning evacuation, coating systems, freeze drying, gas bottle filling/emptying, refrigeration system manufacture, degassing/curing (oil, epoxy resin)

### **Chemical**

- Gel dryers, glove boxes, rotary evaporators, centrifuges, solvent recovery, distillation/extraction/filtration

# nXDS scroll pump sectional view

Optimum bearing placement for long lifetime and easy replacement

High efficiency radial air-gap motor for low power consumption

Wide range voltage input with automatic selection for simple operation

Easy to use manual control buttons

Standby speed control buttons for efficient processtuning

USB port for service use only

Remote control interface for convenience of operation

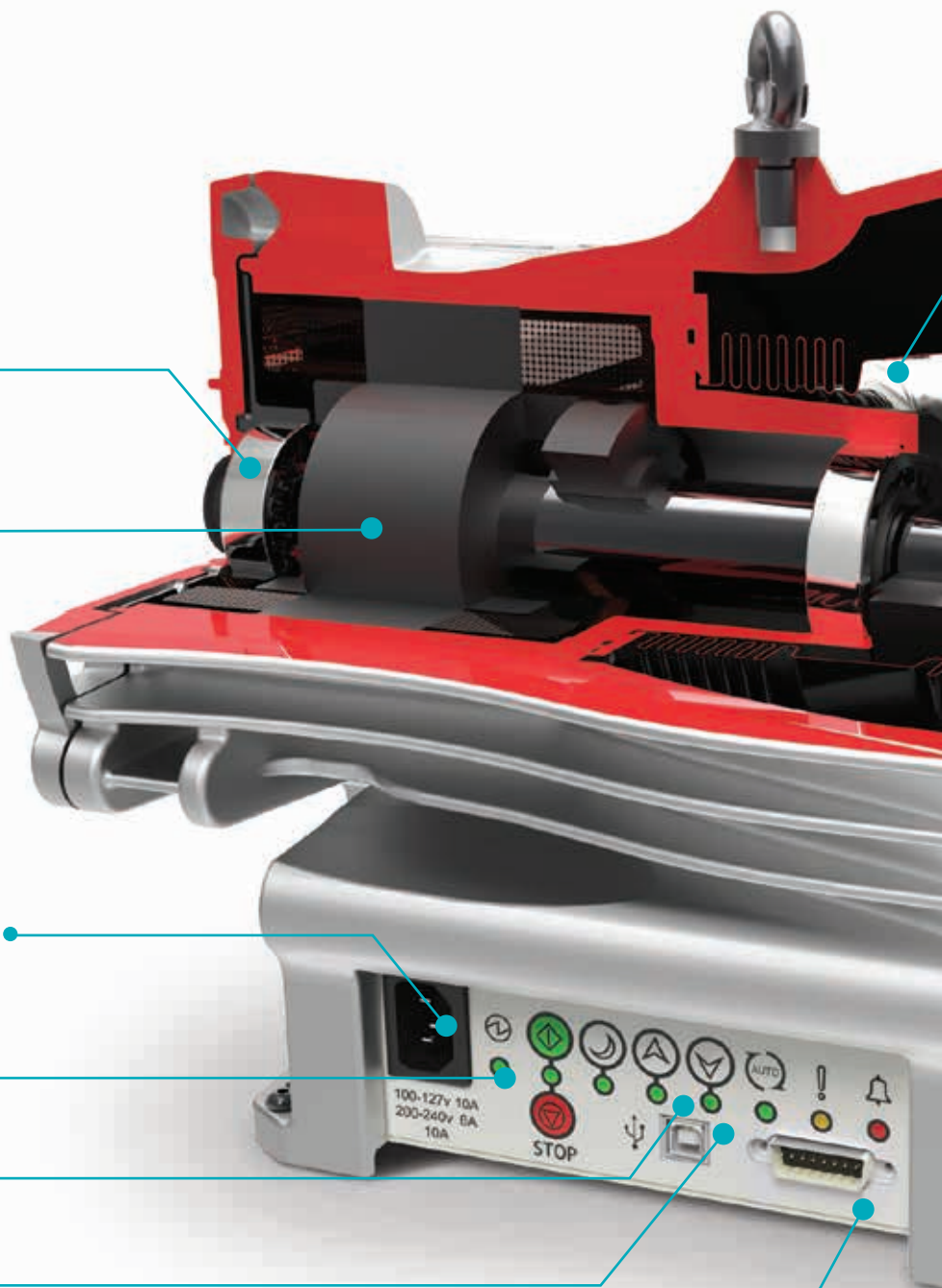

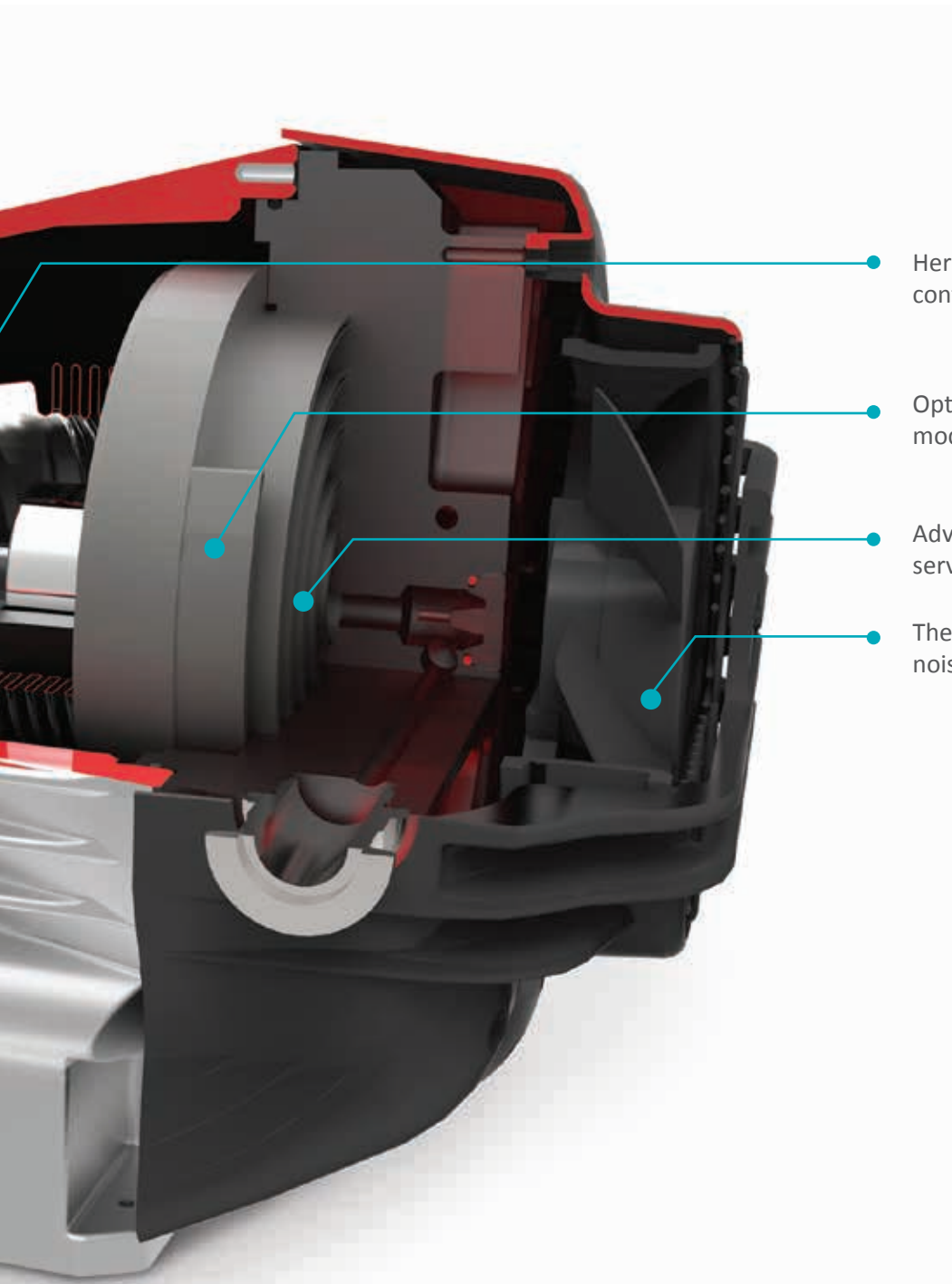

Hermetic bellows sealing for contamination free vacuum

Optimised scroll profiles for each model to maximise performance

Advanced tip-seal technology for long service lifetime

Thermally controlled fan for reduced noise



# Performance

nXDS has been designed to combine the latest advances in scroll technology with an intelligent drive coupled with the long established, truly dry, hermetically sealed mechanism of the XDS series.

Class leading pumping speeds are an improvement over previous XDS models and, with the drive, are of course consistent worldwide. Likewise, ultimate vacuum pressures which are below  $10^{-2}$  mbar are now comparable with those of oil-sealed rotary vane pumps – without the inconvenience of oil.

Hermetic sealing ensures that the vacuum environment is not contaminated by bearing lubricant and, conversely, the bearings are not contaminated by any process gas being pumped.

## Quiet running

The modern laboratory is often a busy place with many other appliances running, all contributing to the background noise. With its low noise power level of 52 dB(A), the nXDS pump makes only a very small contribution to the total noise. This level is up to twenty times less than those of competitor products.

## nXDS is available in four sizes:

- nXDS6i
- nXDS10i
- nXDS15i
- nXDS20i

## Other variants

For more aggressive applications, 'C' Variants are available which feature Chemraz® internal valves and stainless steel fittings for extra protection from the pumped media.

R variants are available for specialist applications such as gas recirculation, rare gas pumping and recovery or other applications where the dilution of the pumped gas is undesirable, or where sealing is integral to minimising potential gas loss.

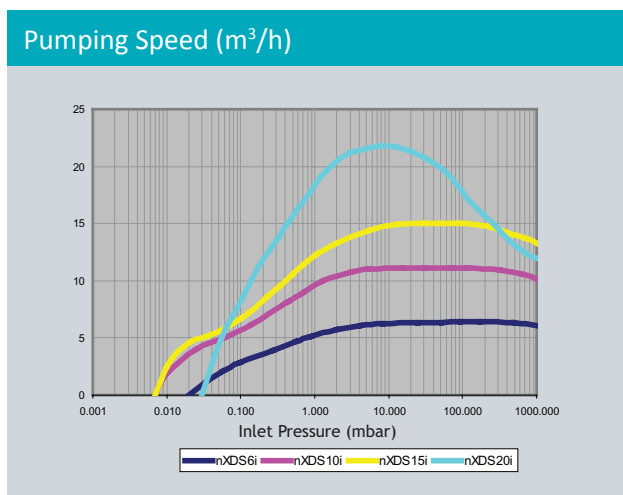

Summary of pump speeds

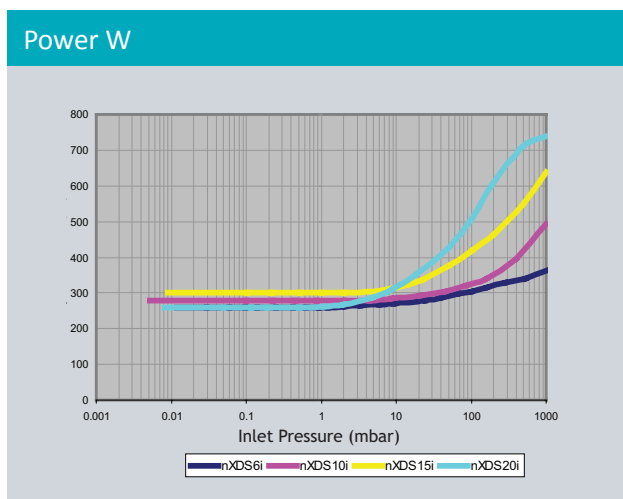

Summary of input powers

# Pump controller

The advanced controller allows for several modes of control:

## Manual

Push button START, STOP and STANDBY. Accurate speed control of 1% of maximum running speed.

## Parallel remote

From your own control system via the 15 way d-sub connector giving the same START, STOP and STANDBY with the option of analogue speed control.

## Serial communication remote

Option of either RS232 or RS485 with a choice of Edwards' proprietary 'DX' protocol or industry standard Modbus protocol. A USB port has been included for service use only.

The pump controller is able to accept voltages from 100-127 and 200-240V (+/- 10%) without the need for intervention.



# Technical data

		nXDS6i	nXDS10i	nXDS15i	nXDS20i
Nominal rotational speed		1800 rpm			
Displacement	m <sup>3</sup> h <sup>-1</sup> (ft <sup>3</sup> min <sup>-1</sup> )	6.8 (4.0)	12.7 (7.5)	17.1 (10.1)	28.0 (16.5)
Peak pumping speed	m <sup>3</sup> h <sup>-1</sup> (ft <sup>3</sup> min <sup>-1</sup> )	6.2 (3.6)	11.4 (6.7)	15.1 (8.9)	22.0 (13.0)
Ultimate vacuum (total pressure)	mbar (Torr)	0.020 (0.015)	0.007 (0.005)	0.007 (0.005)	0.030 (0.022)
Minimum standby rotational speed	rpm	1200			
Speed control resolution (percentage of full rotation speed)	%	1			
Max inlet pressure for water vapour	mbar	35	35	35	20
Max water vapour pumping rate	gh <sup>-1</sup>	110	145	240	220
Maximum continuous inlet pressure	mbar	200	200	200	50
Voltage input	V	100-127, 200-240 (+/-10%)			
Voltage frequency	Hz	50/60			
Motor power 1-ph*	W	260	280	300	260
Power connector 1-ph		IEC EN60320 C13			
Recommended fuse		10A, 250V a.c. rms			
Weight	kg (lb)	26.2 (58)	25.8 (57)	25.2 (56)	25.6 (56)
Inlet flange		NW25			
Exhaust flange		NW25			
Noise level**	dB(A)	52			
Vibration at inlet flange	mms <sup>-1</sup> (rms)	< 4.5			
Leak tightness (static)	mbar ls <sup>-1</sup>	< 1x10 <sup>-6</sup>			
Operating temperature range	°C (°F)	+5 to +40 (+41 to +104)			

\* Typical. See graphs on page 6.

\*\* For low fan speed, typical at ultimate end when load/ambient conditions allow.

## Pumping speed and power curves

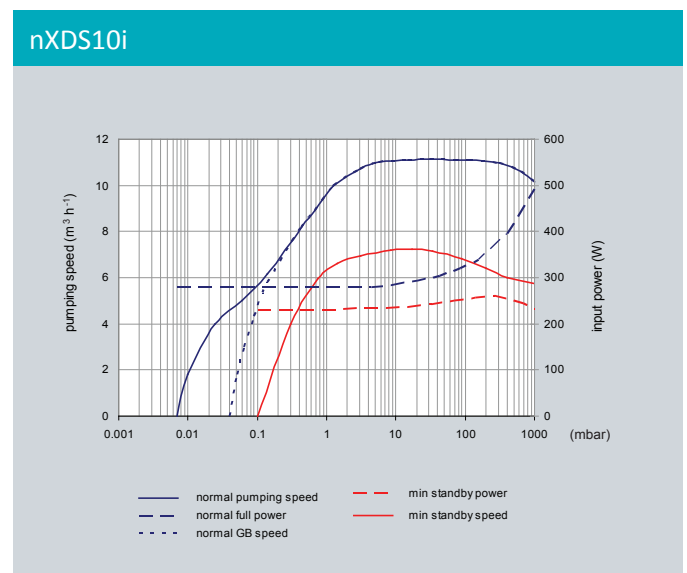

# Dimensions

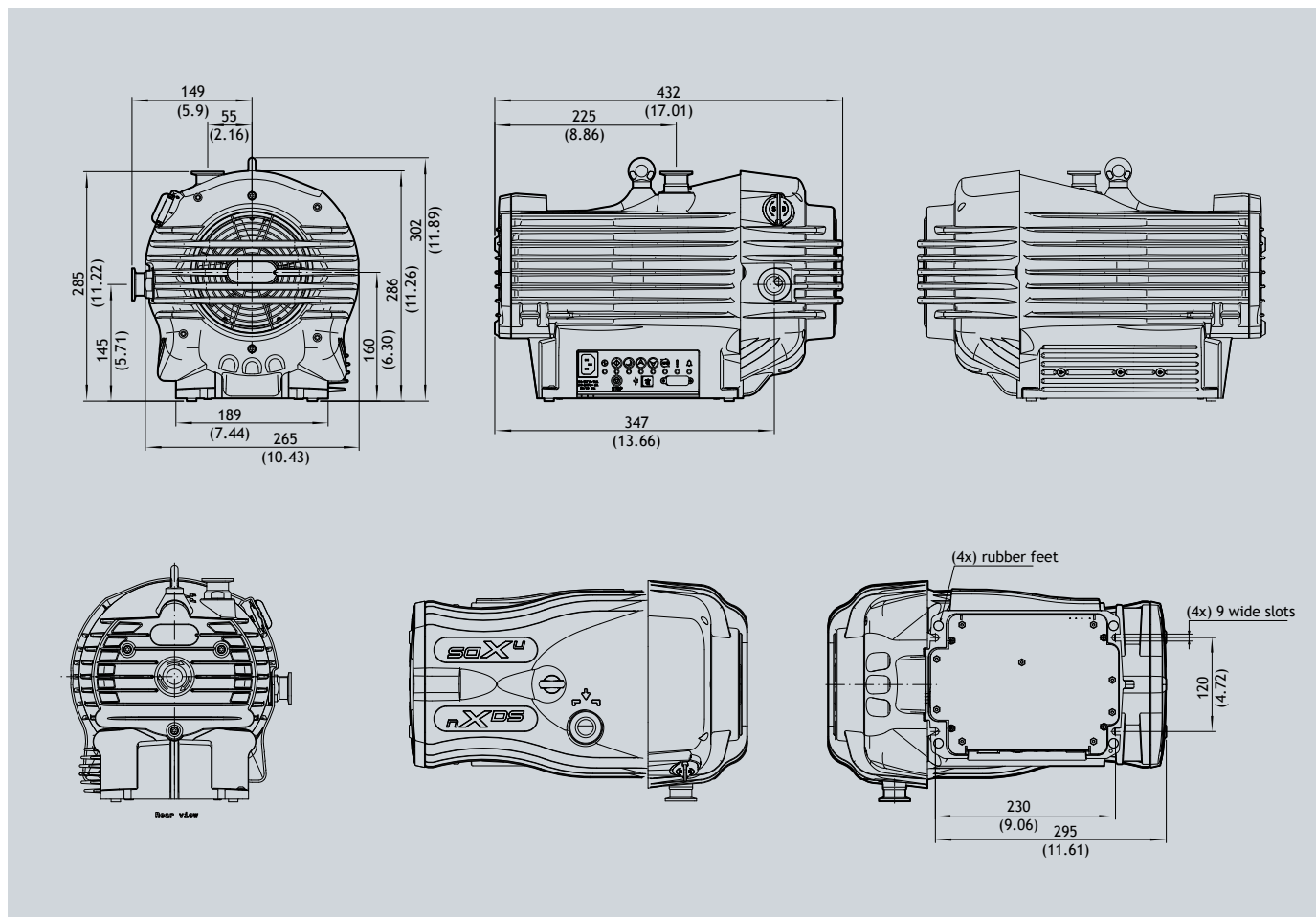

All variants are the same Dimensions in mm (in)



# Controllers

The TIC (Turbo and Instrument Controller) automatically recognises the nXDS pump when connected to the backing pump connector as the controller adopts serial communications mode when connected to the nXDS. There is no need to use a relay box to interface to nXDS.

Speed control and pump run hours etc can be readily accessed from the display. The TIC can also control an nEXT turbopump plus, up to three gauges at the same time as a nXDS pump.

Customers already owning a TIC can upgrade their software to enable interfacing to nXDS.

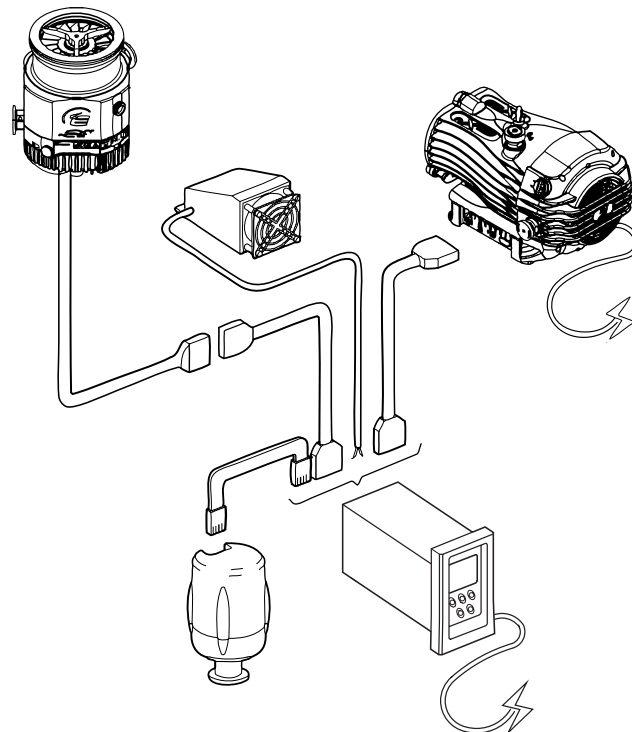

## Ordering information

Standard product		Corrosion resistant (C) variants		(R) Variants without gas ballast	
nXDS6i	A735 01 983	nXDS6iC	A735 02 983	nXDS6iR	A735 03 983
nXDS10i	A736 01 983	nXDS10iC	A736 02 983	nXDS10iR	A736 03 983
nXDS15i	A737 01 983	nXDS15iC	A737 02 983	nXDS15iR	A737 03 983
nXDS20i	A738 01 983	nXDS20iC	A738 02 983	nXDS20iR	A738 03 983

## Spares and accessories

TIC (Turbo) 200W	D397 12 000
TIC (Turbo and Instruments) 200W	D397 22 000
Gas ballast adaptor blank (nXDS)	A735 01 806
Gas ballast adaptor (nXDS) 0.25 mm hole	A735 01 809
Gas ballast adaptor blank (nXDS) no restriction	A735 01 811
Silencer (NW25)	A505 97 000
Inlet/outlet filter 5µm (NW25/NW25)	A505 97 805
Tip seal service kit	A735 01 801
Bearing service kit	A735 01 802

nXDS exhaust and gas ballast kit	A735 01 803
Electrical supply cable 2m, UK	A505 05 000
Electrical supply cable 2m, North Europe	A505 06 000
Electrical supply cable 2m, North America/Japan	A505 07 000
Electrical supply cable 2m, no plug	A505 08 000
TIC interface cable 1.0m	D397 00 835
TIC interface cable 2.0m	D397 00 836
TIC interface cable 5.0m	D397 00 837

## Service

Your business success depends on maximum equipment uptime and minimum total cost of ownership, and we constantly strive to support those objectives. As a global leader in vacuum technology and processes, we understand how vacuum pumps and systems perform in real life. Our wide portfolio of services is designed with you in mind: to help keep your processes and equipment running in the most economical and environmentally efficient manner.

### Services include:

- Overhaul and repair using genuine Edwards OEM parts
- OEM spares and kits available for immediate despatch
- Remanufactured products available for cost-effective expansion and backups
- Global network of expert field service engineers available to respond quickly to unexpected equipment failures
- Extended warranty, to help manage the cost of the unexpected

Our Expert Advantage Service Plans provide you with the on-going support necessary to continuously improve your operational efficiency and meet your business objectives. As service offerings may vary slightly from product to product, please contact your Edwards representative to discuss your specific requirements.





# WolfLabs

**Pricing on any accessories shown can be found by keying the part number into the search box on our website.**

The specifications listed in this brochure are subject to change by the manufacturer and therefore cannot be guaranteed to be correct. If there are aspects of the specification that must be guaranteed, please provide these to our sales team so that details can be confirmed.

**[www.wolflabs.co.uk](http://www.wolflabs.co.uk)**

**Tel : 01759 301142**

**Fax : 01759 301143**

**[sales@wolflabs.co.uk](mailto:sales@wolflabs.co.uk)**

Please contact us if this literature doesn't answer all your questions.